

Memo

Type of product			
Date of purchase			
Name		Tel	
Address			



REVERSE OSMOSIS SYSTEM

RS-105

USER'S MANUAL

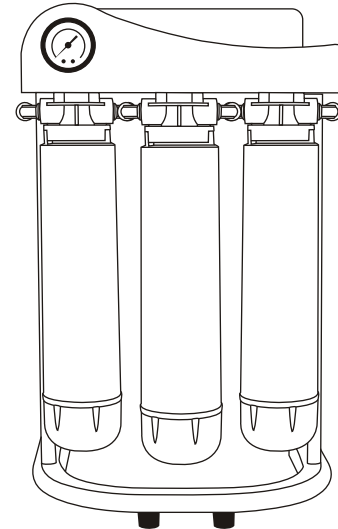

- 01 Introduction of RS-105
- 02 What is reverse osmosis
- 03 Components & Selected filters
- 04 Cartridge filters
- 05 The parts of RS-105
- 06 Tubing connection diagram
- 07 Installation diagram
- 08 Change filters
- 09 Change membrane
- 10 Operation regulation
- 12 FAQ
- 14 Maintenance checkinglist
- 15 Memo

Thank you very much for selecting Pure-Pro Water Corp.
In order to bring the best use of your system, please read the user's manual carefully before installation and follow the regulations.

FAQ

Q: How will the PureProseries water affect mixed beverages?

Because reverse osmosis removes invisible contaminants that mask flavor, it allows the natural taste of your beverages to come through. You will be able to use less coffee and still get the full flavor. Concentrated beverages like orange juice will taste tangier. You will probably be drinking a lot more water as well, since many people drink soda, Kool-Aid, concentrated juices, and beer as an alternative to bad-tasting tap water. Also, PurePro eliminates most of the lime build up on drip coffee makers, preventing the need for frequent cleaning. No longer will you find the white scum on the inside of pans after boiling water.

Q: How much water does the PurePro system produce ?

Under ideal conditions, the TW30-1812-100 TFC membrane is rated at 100 gallons of production per day. Under the average conditions, the consumer can expect 100 gallons of product water per day. But that's still a lot of water for the average household's drinking and cooking requirements.

Q: Don't people need minerals removed from the water ?

Most of the minerals that we receive are from the foods we eat. Only a very small percentage comes from the water we drink.

Q: What is the maintenance schedule for the PurePro system ?

The three pre-filter cartridges should be changed every 6 months. The 5 micron sediment cartridge filter is the first one; the second is a carbon cartridge filter, and the third one is a 1 micron sediment filters. (some systems comes with the Extruded carbon filter.) Failure to change the cartridge every 6 months may cause chlorine to destroy the membrane.

What is reverse osmosis

Reverse osmosis was originally designed to make sea water drinkable for the navy. It is ideal for anyone on a low sodium diet. An R.O. membrane has a pore size much smaller than bacteria virus, or the cryptosporidium parasite. When functioning properly it will remove all microorganisms from tap water and produce sterile water. Reverse osmosis is the reversal of the natural flow of osmosis. In a water purification system, the goal is not to dilute the salt solution, but to separate the pure water from the salt and other contaminants. When the natural osmotic flow is reversed, water from the salt solution is forced to pass through the membrane in the opposite direction by application of pressure-thus the term REVERSE OSMOSIS. Through this process, we are able to produce pure water by screening out the salts and other contaminants.

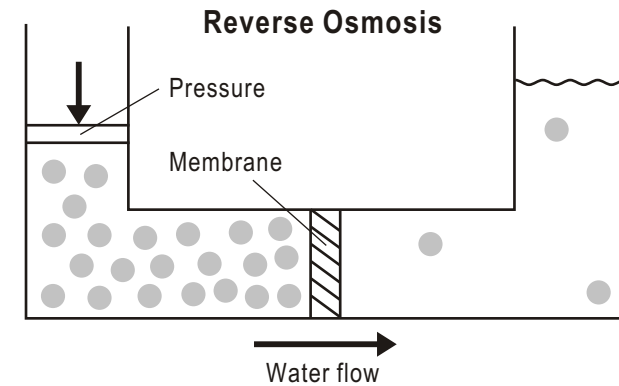

Components & Selected filters

Components

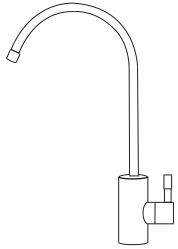

European ceramic faucet

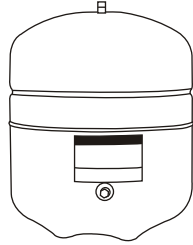

Water storage tank

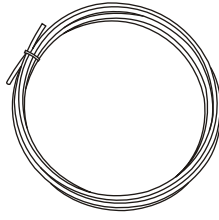

Tubing

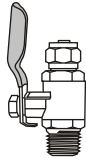

Deliver-valve

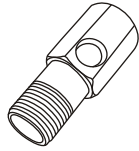

Water supply connector

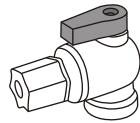

Tankball shut-off valve

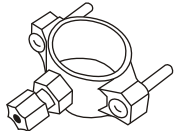

Drain saddle

Selected filters



Mineral cartridge filter

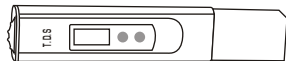

TDS meter



Infra-red cartridge filter



UV water sterilizer

FAQ

Q: What is the guarantee on the PurePro system ?

The PurePro system (excluding filters) is guaranteed for 1 year for material and workmanship. All defective parts will be replaced free within the first year under natural breakdown. The membrane has one year pro-rated guarantee.

Q: What factors affect the quantity and the quality of the water production?

There are four major variables to consider:

- 1. Pressure**-The greater the water pressure, the better water quantity and quality it produced. Water pressure of 60 PSI is ideal.
- 2. Temperature**-76°F is the ideal water temperature for R.O. 40°F water will cause the production of R.O. water to fall to half of that at 76°F. The maximum water temperature recommended is 85°F.
- 3. Total Dissolved Solids (TDS)**-The higher the amount of dissolved contaminants in the water, the lower the quantity of water produced. A high level of TOTAL DISSOLVED SOLIDS can be overcome with additional water pressure.
- 4. Membrane**-Different membranes have different characteristics. Some produce more water than others; some have better contaminant rejection capabilities; some have greater resistance to chemical abrasion for longer life. PurePro system includes TW30-1812-100 The Thin Film Composite (TFC) membranes combine the best of these characteristics and are considered the finest membrane in the world.

Q: Can the PurePro system be connected to an extra faucet?

It only takes a 1/4" tee and tubing to run the water to a refrigerator or a extra faucet. Some families run PurePro system to all of their bathrooms.

Q: What does the PurePro series drinking water taste like?

The taste of the PurePro water depends on the amount of contaminants in the tap water originally. If 95% of dissolved minerals and chemicals are removed, the R.O. water may taste like distilled water (no minerals), bottled water (low mineral), or natural spring water (moderate mineral content).



Operation regulation

- A. With everything connected, turn on the water check for leaks.
- B. Make sure the storage tank shut-off valve is "OFF". Open the sink top faucet.
- C. Within a few minutes (up to 15) the water will start to run from the faucet slowly.
- D. Let the water run for at least 30 minutes. This flushes the carbon filters on first time use.
- E. After initial flushing, open the shut-off valve on the tank and close the sink top faucet.
- F. Tank will now full of water (usually 2 to 3 hours) after the tank has filled. Open the sink top faucet and drain all water until the storage tank is empty and there is only a small flow from the sink top faucet. *** DO NOT USE FIRST TANK OF WATER. ***
- G. Close the sink top faucet. The system is now ready for use.
- H. Change filters regularly every 6 to 12 months and have the membrane checked annually.

Caution

1. Do not use hot water (over 45°C)!
2. Do not freeze the machine!
3. Switch off electricity and water source if away for more than 5 days, and drain out pure water.

Cartridge filters

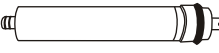
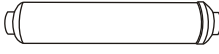
Cartridge Filters	Filter Description	Service Life
<p>Stage 1 5 Micron Sediment Filter</p> 	<p>RS300ST With only five micron rating. It is effective in removing dirt, rust and sand particles.</p>	6 Months
<p>Stage 2 GAC Carbon Filter</p> 	<p>RS300ND It takes out 99% of the chlorine and organic chemicals. It provides enhanced reduction of taste, odor, and color.</p>	6 Months
<p>Stage 3 CTO Carbon Filter</p> 	<p>RS300RD It takes out 99% of the chlorine and organic chemicals. It provides enhanced reduction of taste, odor, and color.</p>	6 Months
<p>Stage 4 TFC Membrane</p> 	<p>A thin film composite (TFC) high quality membrane that processes 100 gallons per day. It remove the following hard water contaminants that may be present in your water: lead, cooper, barium, chromium, mercury, sodium, cadmium, fluoride, nitrite, nitrate, and selenium.</p>	2 Years
<p>Stage 5 Post Carbon Filter</p> 	<p>This carbon post filter removes objectionable tastes and odors to enhance the quality of your drinking water. We are using NSF approved post carbon to guarantee the taste of water.</p>	1 Year

The parts of RS-105

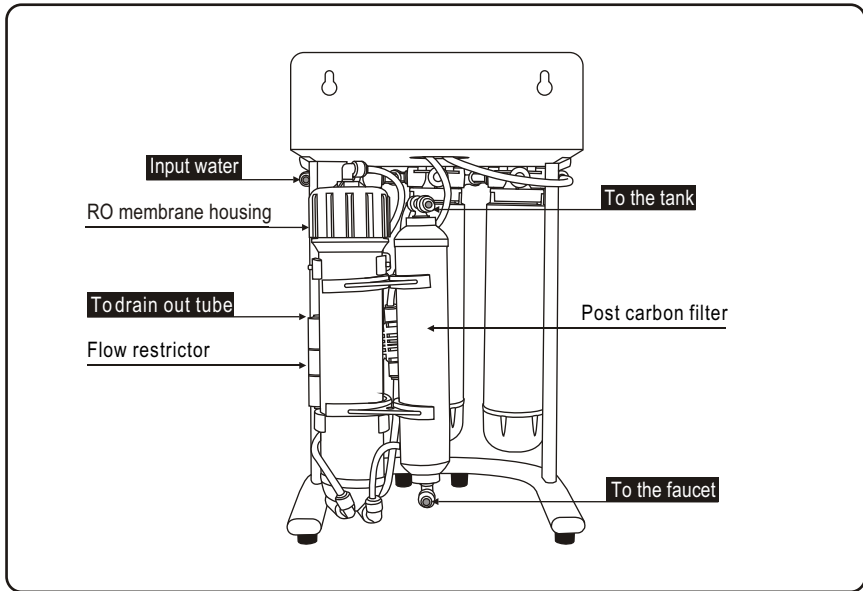
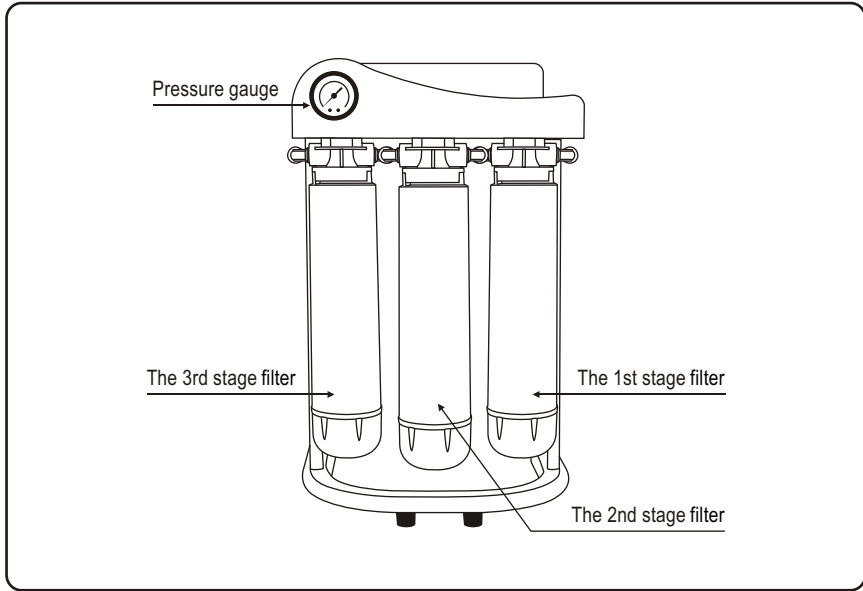

RS-105 Reverse Osmosis Drinking Water Systems

Operation regulation

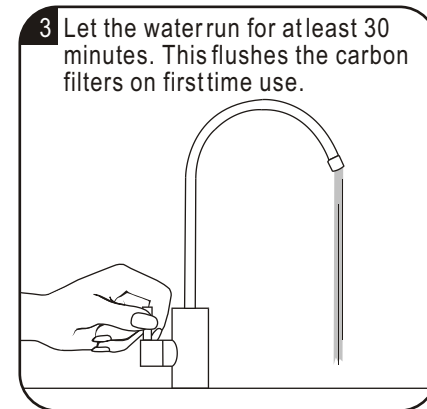
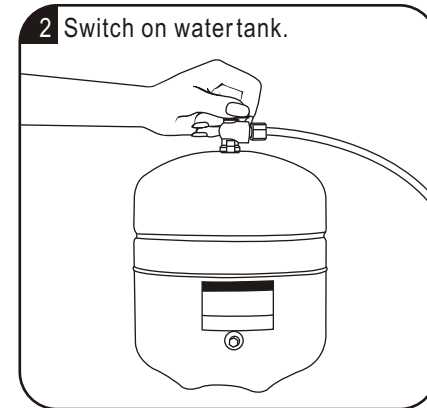
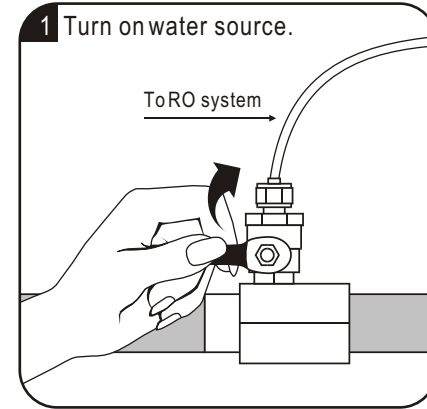

RS-105 Reverse Osmosis Drinking Water Systems

Change membrane

1 Turn off water source.

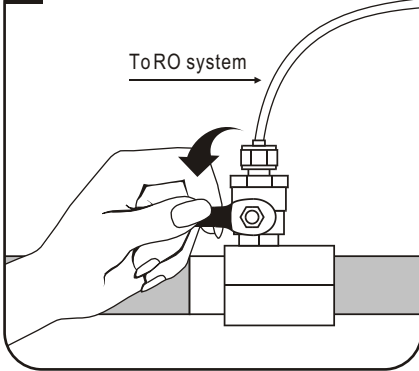

2 Switch off water tank.

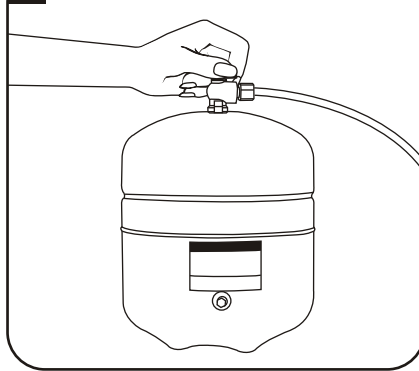

3 Remove the tube.

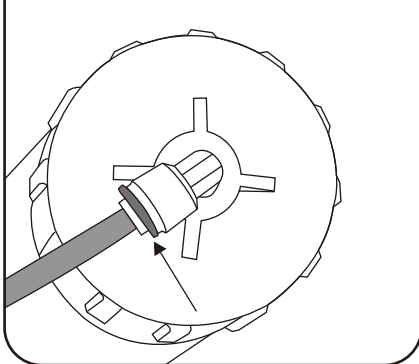

4 Remove the membrane housing cap anticlockwise.

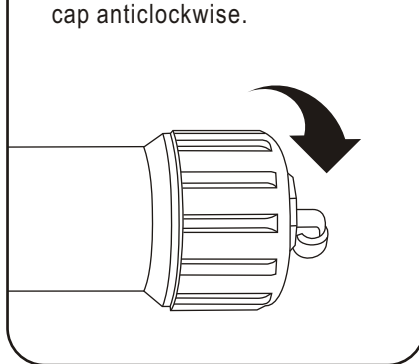

5 Remove the membrane by a pincer.

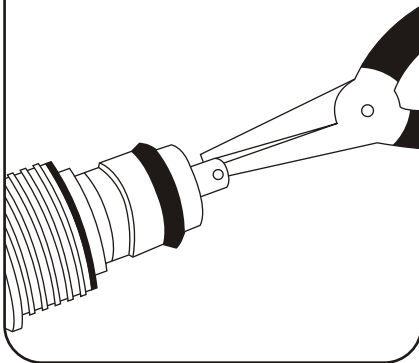

6 Install the membrane by carefully pushing the spigot end into the socket at the far end of the housing until completely in.

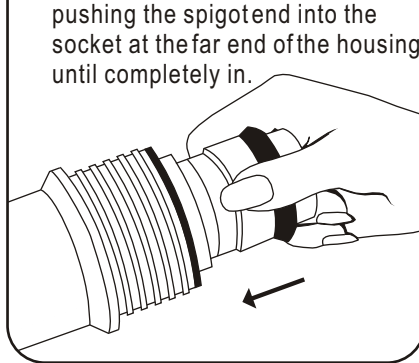

RS-105 Reverse Osmosis Drinking Water Systems

PUREPRO
DRINKING WATER SYSTEM

Tubing connection diagram

CONNECTING THE COLOR TUBING:

- A. Connect the WHITE tubing to the water supply connector.
- B. Connect the BLUE tubing to the sink top faucet.
- C. Connect the BLACK tubing to the drain saddle.
- D. Connect the RED tubing to the storage tank.

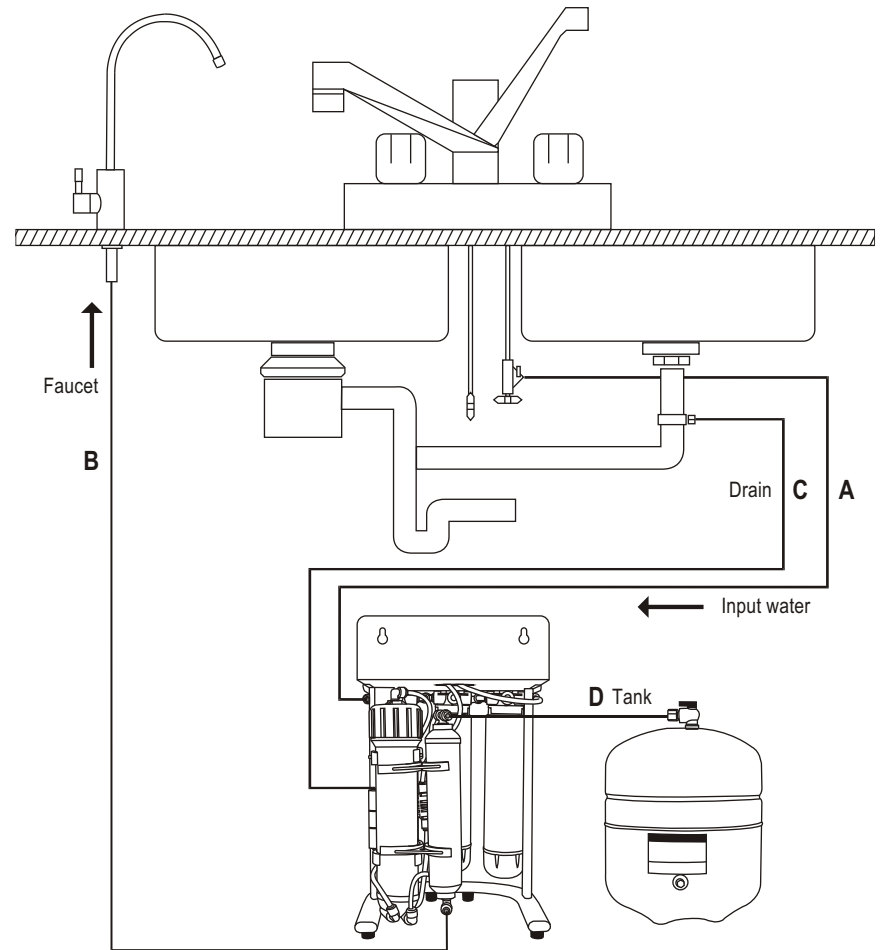

RS-105 Reverse Osmosis Drinking Water Systems

PUREPRO
DRINKING WATER SYSTEM

Installation diagram

Input water :

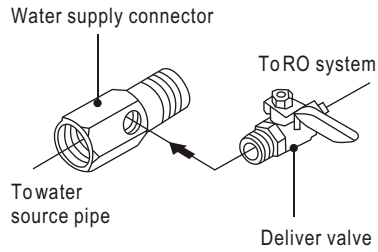

Install water tank :

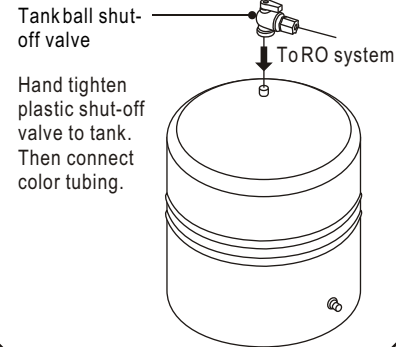

Install faucet :

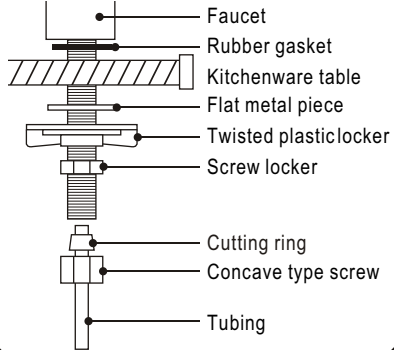

Install drain saddle :

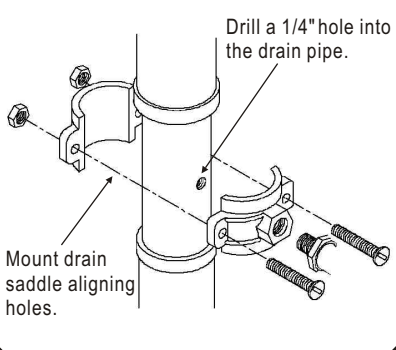

Assemble membrane :

- Remove the tube.
- Remove the membrane housing cap.
- Install the membrane by carefully pushing the spigot end into the socket at the far end of the housing until completely in.

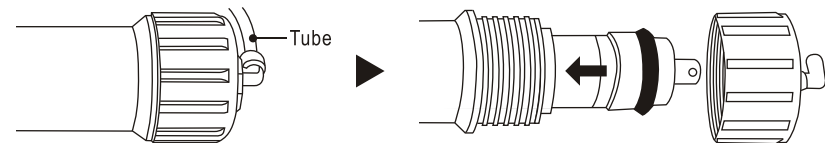

Change filters

1 Turn off water source.

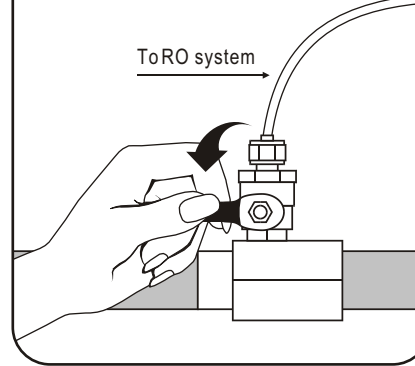

2 Switch off water tank.

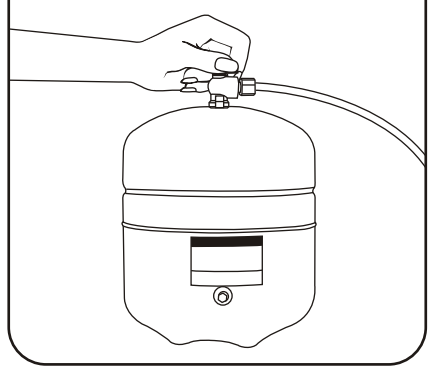

3 Loose the used pre-filter clockwise and remove it.

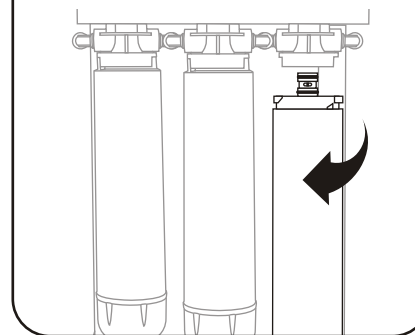

4 Screw in and install the new filter anticlockwise.

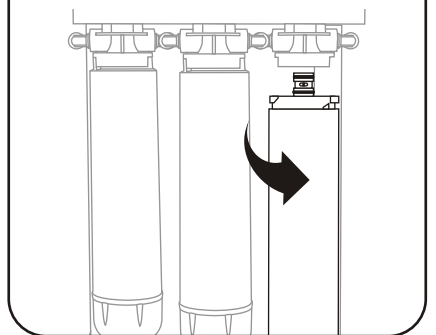

5 Drain out 1 Gallon of water to purify replacement filters.

